

Concord

Community TV



Building

Partnerships



Annual Report 2003-2004

From the Board Chair

Partner Up!

Building partnerships has long been a goal of CCTV. There are numerous, multi-talented people who produce a broad range of CCTV shows, but they can only do so much. CCTV needs you. The opportunity is available for you, your friends, group, or organization to join in and “partner up” with CCTV to do a show. You can get your ideas, view point and perspective out through your cable access television show.

CCTV seeks to inform, entertain and challenge Concord viewers with its programming. Yet, we want our shows to reflect, spotlight, and highlight the Concord viewing community and their interest. This means you. We want to draft you to partner up.



You supply the idea and energy for your new show, along with a volunteer or two. CCTV will provide the experience and training to help you mold it into a finished product. That’s “partnering up.”

Synergy is when the whole is greater than the sum of the parts. Kind of like two plus two equals five. Obviously, bad math, but the Concord community really wins when you and your group join with CCTV for a new show and create synergy. Hobbies, clubs, cooking and multi-cultural themes are a few potentially new shows that need hosts, producers and volunteers.

This past year Concord’s Educational Channel 6 grew like Jack’s beanstalk and highlighted the talents and activities of our Concord school students.

So put synergy to work for you and your group. “Partner up” with CCTV and have fun too. You can be the “on camera host” waiting for the red light to go on, or work behind the scenes. Become a star of your hometown cable station. Ready for a new challenge? Well, “partner up.”

Charlie Russell

“We want our shows to reflect, spotlight, and highlight the Concord viewing community and their interest.”

Board members and staff attended an all-day retreat to set goals for and plan the future of the organization.



About the Cover

The cover photos represent a sampling of the many ways that CCTV partners with others in our community.

SeniorSpeak NH (top left photo-Gus the Clown) is but one of several senior citizen programs produced for CCTV’s Public Access Channel 22.

CCTV actively participates with the Concord Boys and Girls Club Auction each year (center photo), helping the organization raise thousands of dollars through technical support and cablecasting of the event on Channels 22 and 6.

Merrimack Valley High School volunteers produce *A View from the Valley* (bottom left-MVHS student singers) which is the result of CCTV’s efforts to expand educational programming.

2003-2004 Board of Directors

Charles Russell, Chair
Anthony Tenczar, Vice Chair
William Stetson, Treasurer
Marilyn Fraser, Secretary
Keith C. Allberg
Allen Bennett
Lorrie J. Carey
Lorne Gregory
Kent W. Hemingway
Patricia A. Immen
Rose Marie Lanier
Robert Monson
Robert Moses
Barbara O’Brien
Eugene Rudolph
Lucilla Sokol

Attorney at Law
Asst. Prof. of Communications, UNH
Sec./Treas. New Hampshire AFL-CIO
Former City Councilor and State Rep.
Concord City Councilor
Concord City Councilor
Pres., Marshall’s Flowers and Gifts
Dir. of Ticketing Services, CCA
Principal, Kimball School
Library Dir., Concord Public Library
Pres., Concord Communications
Dir. of Facilities, Concord School Dist.
Sr. V.P. Legal, Oxford Health
Educator
Retired Owner, Litetrol Services
Educator

From the Executive Director

Concord Community TV is very pleased to have “Building Partnerships” as its theme for our Annual Report.

During the 2003-04 fiscal year, our facility was proud to partner with several organizations and institutions in hopes of establishing a foundation for other future relationships. On our Government Channel, several departments, including Police and Fire, Library, Personnel, Housing, Purchasing, General Services and Recreation, utilized our studio to disseminate information through video programming and bulletin board messaging. On our Education Channel, private and state schools joined with the Concord School District to communicate their programs, news and student achievements. And, on our Public Access Channel, many entities, including the Society for the Prevention of Cruelty to Animals, Concord Hospital, Dartmouth-Hitchcock Medical Center, Main St. Concord, Centennial Senior Center, Capitol Center for the Arts, Concord City Auditorium, Concord Boys and Girls Club, Amercian Red Cross, Chamber of Commerce, Rotary Club, Kiwanis Club, Council of Churches, Visiting Nurse Association, Merrimack Valley Society of Genealogists and the Merrimack County Visitation Center, discovered the various ways to reach out to their public audience.

Our first major fundraiser, “Let Freedom Sing!”, was the result of an intensive effort to make the community aware of our mission and how we can help achieve its goals. Several companies joined in our cause to improve our facility with state of the art equipment, thus improving the technical quality of our programming.

“Building Partnerships” also includes individuals and the many residents and students of our city who care deeply about its future. CCTV thanks all those who have donated their time, energy and funds to volunteering, supporting and/or producing programs for our channels.

CCTV believes that our city grows and strengthens when all entities cooperate and work together toward one goal: the betterment of our community. We hope we can provide a vital and important medium through which all can communicate, inform and instruct. We invite all residents, government and school employees and non-profit organizations to take advantage of this exciting resource.

Steve Budkiewicz



Cablecasting

Video Programming:

9,646 hours @ \$200 ph = \$ 1,929,200

Community Bulletin Board:

7,800 messages @ \$10 per message = \$ 78,000

Volunteerism

Program Production:

2,174 hours @ \$225 ph = \$ 489,150

Board of Directors:

700 hours @ \$25 ph = \$ 17,500

Remote Equipment Usage

Camcorder Packages:

150 @ \$50 per usage = \$ 7,500

Remote Production Unit:

20 @ \$200 per usage = \$ 4,000

Studio Training and Editing

Studio Training and Production:

260 hours @ \$100 ph = \$ 26,000

Editing Stations:

520 hours @ \$15 ph = \$ 7,800



**2003-2004
Approximate Dollar Value
Contribution
to the Community**

\$2,559,150



Partnering with Schools

In November 2003 the New Hampshire Charitable Foundation awarded a \$4,000 grant to CCTV to expand its educational programming. The grant funded the publication and mailing of an educational brochure, purchase of furniture and backdrop for the “Education Matters” studio set, expenses for an educational focus group meeting and purchase of a GL2 Camera and accessories. Thanks to this funding, new video equipment is available for Concord school productions, an Educational Advisory Group provides direction and focus, and programming on the Education Channel 6 continues to flourish.



“CCTV has given the Concord School District staff, students and parents the opportunity to work together in new ways. We have valued CCTV’s airing of School Board meetings, school events, and special programs. Testimony to the value of this partnership came last spring from a grandmother who was unable to attend her grandson’s musical concert because of illness. She wrote that she so appreciated that she could watch her grandson’s performance on CCTV. We look forward to exploring and expanding the possibilities of this partnership in the future.”

Dr. Christine Rath, Superintendent of Schools

Funded by a New Hampshire Charitable Foundation grant, a group of parents, students and teachers from Concord schools took part in an educational focus group which provided valuable input toward expanding educational programming.



Partnering with Government



Partnering with the government to help it reach out to its citizens, CCTV continues to be a vital part of the city's communication efforts. The station's commitment to the community in cablecasting City meetings each month or videotaping special events, such as Neighborhood Forums and Master Plan sessions (shown in photo), has ignited and increased viewership by those who wish to be kept informed on local issues.

"The City's partnership with CCTV continues to flourish with more programming and greater creative assistance that continue to please and inform our viewing public. From providing additional programming featuring Mayor Donovan and additional Police, Fire, and Recreation Department shows to partnering with the City in emergency management broadcasting, CCTV continues to expand the City's ability to get our message out. Congratulations on another successful year."

Duncan Ballantyne, Concord City Manager

Statement of Activities

For the year ended June 30, 2004

<u>Support and Revenue</u>		<u>Expenses</u>	
<u>Support</u>			
Franchise Fee	\$ 189,116	Program services	91,782
Grants and fundraising	12,564	Outreach	55,800
Other contributions	1,495	Administration	<u>83,053</u>
In-kind rent	23,776	Total expenses	<u>230,635</u>
Miscellaneous income	<u>3,908</u>		
Total Support	<u>230,859</u>	Change in Unrestricted Net Assets	4,015
		Unrestricted Net Assets, beginning of year	<u>141,615</u>
<u>Revenue</u>		Unrestricted Net Assets, end of year	<u>\$ 145,630</u>
Service fees	2,921		
Interest income	<u>870</u>		
Total Revenue	<u>3,791</u>		
Total Support and Revenue	<u>234,650</u>		

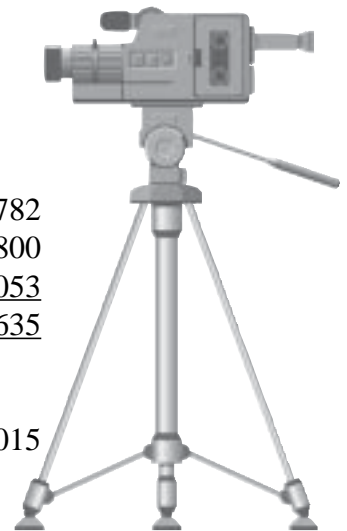



Partnering with the Public

The following individuals from the community donated an impressive number of hours during the 2003/2004 fiscal year. A total of 189 people volunteered more than 5,600 hours in television production, fundraising activities and serving on the CCTV board and committees. In addition, 286 guests visited the studio, appearing on community produced programs .



Dodji	Aboussa	Alex	Coffin	Jim	Greary	Chris	Leboe	Ben	Scheffer
Keith	Allberg	Julia	Coffin	Jon	Greenberg	Elizabeth	Lent	Kyle	Schoefield
Russell	Allen	Andy	Collins	Eric	Green	Keith	Lewin	Susan	Schott
Steve	Ambra	A.D.	Copestakes	Charlotte	Greene	Ceriden	Lewin	Doug	Schwarz
Chris	Anu	J.	Coughlin	Lorne	Gregory	Erin	Linnell	Madeleine	Shea
Anita	Arbo	Daron	Creighton	Sue	Gunther	Paul	Manning	David	Shore
Alice	Arsenault	Michael	Curtiss	Agnes	Hagan	Tara	Marvel	Jeff	Siegel
Charles	Arsenault	Peter	Daneau	Elizabeth	Hager	David	McDonald	Andrew	Sokol
Judy	Arsenault	Peg	Daneau	Carol	Hargrove	Lindsay	McGee	Elisabeth	Sokol
Lucy	Arsenault	Lee	Delfausse	Hannah	Harmon	Joanne	McGlynn	Henry	Sokol
Tom	Aspell, Jr.	Kai	deMello-Folsom	George	Harrington	Steve	Meier	Lucilla	Sokol
Jason	Atton	Ellen	Desmond	Jim	Harvey	Jane	Meier	Stan	Sokol
Carol	Bagan	Dave	Desmure	Rob	Hawk	Matt	Mercier	Janet	Sprague
Merwyn	Bagan	Grant	Dillon	Carolyn	Hemingway	Robert	Monson	Marcia	Sprague
Duncan	Ballantyne	Jessie	Dulude	Kent	Hemingway	Robert	Moses	Mark	Stanko
Norm	Ballard	Alex	Duncan	Scott	Horner	David	Murdo	Barry	Steelman
Vincent	Barbetta	Karen	Duncan	Kevin	Howland	Gloria	Najecki	Bill	Stetson
Jean	Barker	Katie	Duncan	Pat	Immen	Mark	Novembrino	Tom	Tasker
Johanna	Barry	Jack	Duncan	Sarah	Jacobs	Barbara	O'Brien	Shayne	Temple
Mike	Barwell	John	Duncan	Tom	Jaskiewicz	Michael	Orsillo	Anthony	Tenczar
Kevin	Belval	Chuck	Edmonds	Stephanie	Judge	Cindy	Ouellette	Brian	Teune
Allen	Bennett	Grant	Edwards	Pat	Kaplo	Aime	Ouellette	Joanne	Teune
John	Bibaud	Wayne	Eldridge	Nancy	Keane	Scott	Owen	Barbara	Thomas
Carissa	Black	Brent	Erickson	Eileen	Keim	David	Page	Carol	Thomson
Carrie	Block	Marci	Eschenbach	Jon	Kelly	Debra	Patten	Michelle	Tiffany
Adam	Boivin	Michael	Eschenbach	Roberta	Kelly	Dick	Patten	Donna	Trapp
Brooke	Bouldry	Susan	Foster	Karen	Kenney	Bob	Pingree	Dorothy	Trapp
Roger	Brooks	Sally	Foster	Sharon	Kidspot	David	Poisson	Dick	Utell
Ryan	Brown	Jeff	Fox	Kent	Kiehl	Gwendolyn	Poppe	Jason	Varnell
Catherine	Buck	Marilyn	Fraser	Paige	Kingsley	Jim	Readey	Craig	Walker
Wayland	Bunnell	Ryan	Frederickson	Clint	Klose	George	Reynolds	Jean	Wallin
Peter	Burgess	Norene	Freeman	Leah	Kosow	Dan	Rigsby	Dick	Ward
Bob	Camerand	Skip	French	Mark	Kritlow	Connie	Rosemont	Sarah	Ward
Lorrie	Carey	Chrissy	Fulton	Chris	Laboe	Gene	Rudolph	Rick	Watrous
Dan	Champagne	Dan	Gauthier	John	Labrie	Charlie	Russell	Candace	White-Bouchard
Byron	Champlin	Chris	Gentile	Linda	LaBrie	Bill	Ryan	Bob	Williams
Paul	Clements	Emily	Gilbert	Robbie	LaBrie	Ann	Saunderson	Michael	Zingarelli
Jenni	Cluff	Jessie	Gilbert	Rose Marie	Lanier	George	Saunderson		

Community Support

A Growing Partnership

As CCTV grows, so does support from the community. In December 2003, the “Friends of CCTV” Annual Campaign Drive generated a total of \$2,375, thanks to the generosity of the following individuals:

Visionary Level

Ray and Rose Marie Lanier,
in memory of Blanche and David Tyson

Gold Level

Robert Moses
Stan and Lucilla Sokol,
in memory of Dymetro Mysyk

Silver Level

Charles Bauer
Douglas Black, M.D.
Dr. Roger Brooks
Concord High TV Production Club
Robert Govostes
Jon Kelly
Karen Anne Kenney
Frances Leitgeb

Pam Power and Anthony Tenczar
Dr. and Mrs. R.C. Rainie
Gordon and Cy Sherman
Dr. Robert W. Williams

Business Friends

Concord Coin and Antiques
Donna Nordlund, Bead It!

In January, 2004, The Bagan Foundation awarded a \$2,500 grant for the purchase of a Canon GL-2 digital camera and accessories to “provide the quality signal needed in the studio, as well as for remote productions such as government meetings, school, community, and cultural events.”

Sponsorships for the musical fundraiser “Let Freedom Sing!” generated \$3,500 in revenue and \$2,000 in-kind donations in FY2003-2004 from the following businesses:

Gold Sponsors:

Merrimack County Savings Bank
Northeast Delta Dental
Pleasant View Retirement
Wallace Press

Silver Sponsors:

Advantage Signs
Bow Mills Bank
Capitol Copy
Jefferson Pilot Financial



In June, 2004, CCTV received a \$1,000 one-time “thank you contribution” from the United Way of Merrimack County, recognizing the station’s “importance to our community and to all the things United Way represents.”

CCTV

170 Warren St
Concord, NH 03301
Phone: 603-226-8872
Fax: 603-226-3343
www.ConcordCCTV.Com

Non Profit Org
U.S. Postage
PAID
Concord, NH 03301
Permit #1557

CCTV Mission Statement

To provide residents, city government and educational and nonprofit organizations of Concord, New Hampshire, and such surrounding towns that may elect to participate, with the opportunity, facilities and access to cable television for the purpose of producing and cablecasting public interest, cultural, education and government programs over the local cable television channels.

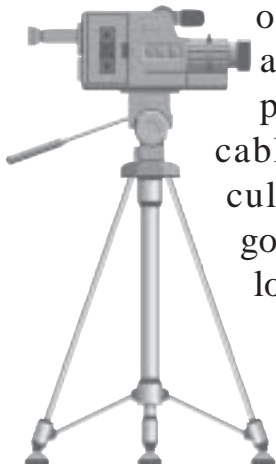

“Main Street Concord, Inc. is appreciative of the many opportunities we’ve had to partner with CCTV. Thanks to your public service programming, we have been able to talk about Main Street Concord’s mission, goals, objectives and activities on a variety of Channel 22 programs. We look forward to working together in the future.”

*Nan Hagen
Executive Director
Main Street Concord, Inc.*